

Drawbar trailer Air Brake and Suspension System with TEBS G2.2 Premium (4S/3M brake system with TEPM-P, air suspension system with 2 raise/lower valves and TIM G2)

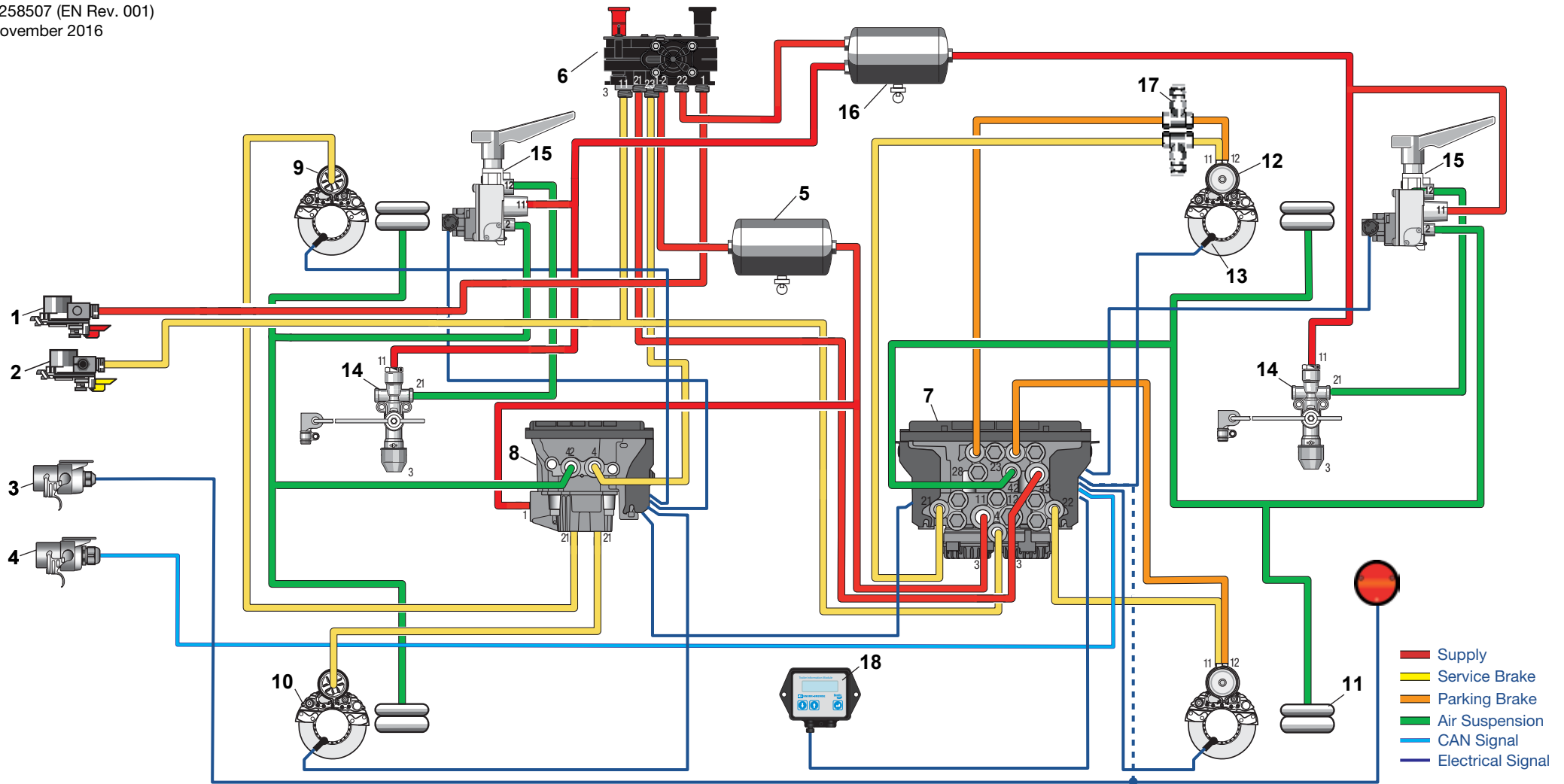

Y258507 (EN Rev. 001)
November 2016



- | | | | |
|--|--|--|--|
| 1 Coupling Head "Supply" with Filter | 6 Park/Shunt Valve with integrated Charging Valve and Front Axle Release Valve | 10 Air Disc Brake | 15 Raise/Lower Valve with Reset-to-Ride Height |
| 2 Coupling Head "Control" with Filter and Test Connector | 7 TEBS G2.2 Brake Module - Premium | 11 Air Suspension Bellows | 16 Air Reservoir (Air Suspension) |
| 3 ISO 12098 Connector | 8 Trailer Electro-Pneumatic Module - Premium (TEPM-P) | 12 Spring Brake | 17 Test Connector |
| 4 ISO 7638 Connector (EBS) | 9 Brake Chamber | 13 Sensing Ring and Wheel Speed Sensor | 18 TIM G2 |
| 5 Air Reservoir (Service and Parking) | | 14 Levelling Valve (without Height Limitation) | |